

Technical Note

# Installing in a 50 Amp Service

PROsine 2.5/3.0

512-0009-01-01 Rev 1

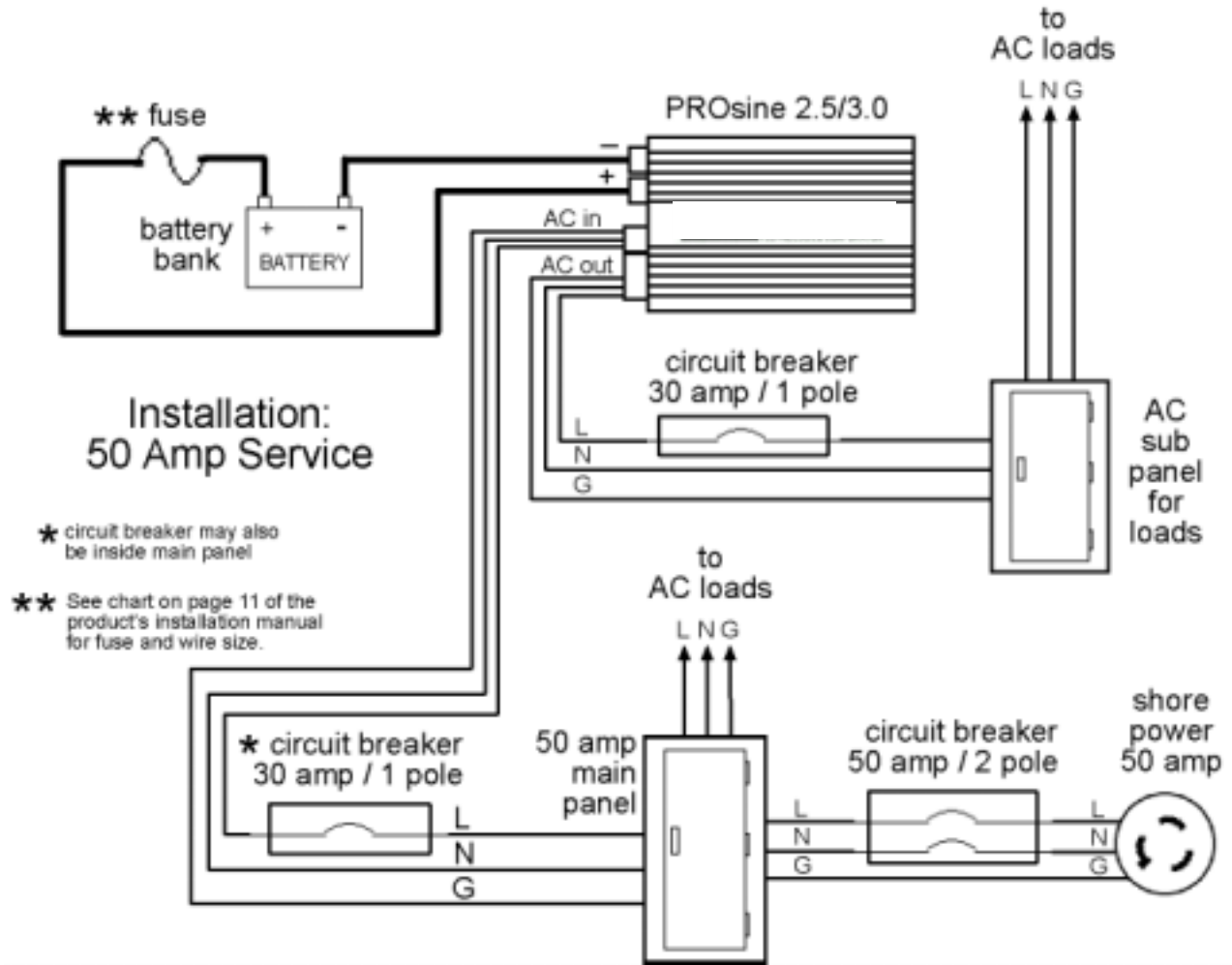

PROsine is a trademark of Xantrex International. Xantrex is a registered trademark of Xantrex International.  
© 2002 Xantrex International. All rights reserved.

Technical Note *Prosine 2.5/3.0 Installing in a 50 Amp Service*: © December 1998 Xantrex International

UNLESS SPECIFICALLY AGREED TO IN WRITING, XANTREX TECHNOLOGY INC. ("XANTREX"):

(a) MAKES NO WARRANTY AS TO THE ACCURACY, SUFFICIENCY OR SUITABILITY OF ANY TECHNICAL OR OTHER INFORMATION PROVIDED IN ITS MANUALS OR OTHER DOCUMENTATION.

(b) ASSUMES NO RESPONSIBILITY OR LIABILITY FOR LOSS OR DAMAGE, WHETHER DIRECT, INDIRECT, CONSEQUENTIAL OR INCIDENTAL, WHICH MIGHT ARISE OUT OF THE USE OF SUCH INFORMATION. THE USE OF ANY SUCH INFORMATION WILL BE ENTIRELY AT THE USER'S RISK.

Part number: 512-0009-01-01 Rev 1

Contact information:

**Phone:** 1-800-670-0707 (toll-free in North America)

**Phone:** 1-604-422-2777 (direct)

**Fax:** 1-604-420-2145 (direct)

**Email:** [CustomerService@xantrex.com](mailto:CustomerService@xantrex.com)

**Web:** [www.xantrex.com](http://www.xantrex.com)